

NEW

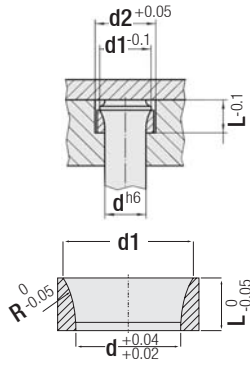

Mounting Ring for Bottle-neck Punch Code: G162

"G162" is used for more practical mounting of Bottle-neck Punches on the retainer plate.

Advantages:

- * Cylindrical counter bore in the retainer plate is sufficient.
- * Tempered Mounting Ring reduces the shrinking in the untempered retainer plate.
- * You can take advantage of the positive features of Bottle-neck Punches without complex installation.

Material: Tempered Steel

Order Code	d mm	d1 mm	d2 mm	L mm	L1 mm	R mm
G162.30	3.0	4.5	6	7	4	6.5
G162.35	3.5	5.0	7	7	4	8
G162.40	4.0	5.5	7	8	4	8
G162.50	5.0	7.0	9	11	7	10
G162.51	5.1	7.0	9	11	7	10
G162.55	5.5	8.0	10	11	7	10
G162.60	6.0	9.0	11	11	7	10
G162.65	6.5	10.0	12	11	7	12
G162.70	7.0	10.0	12	11	7	12
G162.75	7.5	11.0	13	11	7	12
G162.80	8.0	11.0	13	12	8	12
G162.85	8.5	13.0	15	12	8	15
G162.90	9.0	13.0	15	12	8	15
G162.95	9.5	14.0	16	12	8	15
G162.100	10.0	14.0	16	13	9	15
G162.110	11.0	15.0	17	13	9	15
G162.120	12.0	16.0	18	13	9	15
G162.130	13.0	17.0	19	13	9	15
G162.140	14.0	18.0	20	13	9	15
G162.150	15.0	19.0	21	13	9	15
G162.160	16.0	20.0	22	13	9	15
G162.170	17.0	21.0	23	13	9	15
G162.180	18.0	22.0	24	13	9	15
G162.190	19.0	23.0	25	13	9	15
G162.200	20.0	25.0	27	14	10	15

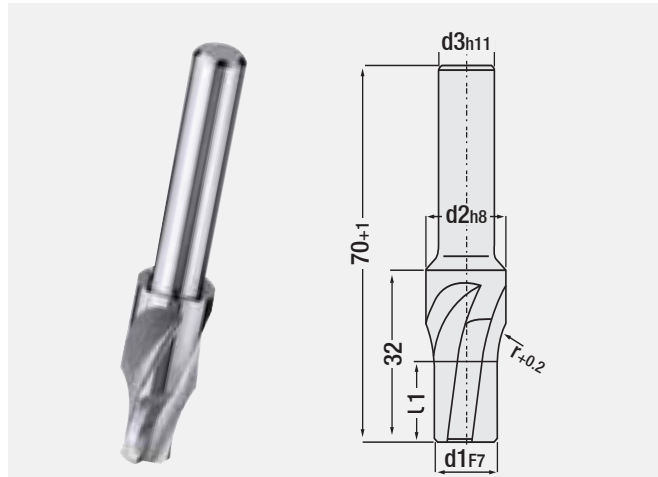

Piloted Counterbore Punch Code: UFT (for tapered head)

d1	d2	d3	r	l1	x (d1)
2.0	3.3	3.3	3.5	5	01
2.1 ~ 2.2	3.5	3.5	5.0		
2.3 ~ 2.5	3.8	3.8	5.0		
2.6 ~ 2.9	4.3	4.3	6.0	7	
3.0 ~ 3.4	4.9	4.9			
3.5 ~ 3.9	5.4	5.4	8.0	8	
4.0 ~ 4.4	5.9	5.9			
4.5 ~ 4.9	6.4	6.4			
5.0 ~ 5.4	7.4	7.4	10	10	
5.5 ~ 5.9	8.5	8.5			
6.0	9.5	10	12	12	05
6.5 ~ 7.0	10.5				
7.5 ~ 8.0	11.5				
8.5 ~ 9.0	13.5		15	15	
9.5 ~ 10	14.5				
10.5 ~ 11	15.5				
11.5 ~ 12	16.5				
12.5 ~ 13	17.5		16	15	
13.5 ~ 14	18.5				
14.5 ~ 15	19.5				
15.5 ~ 16	20.5				
16.5 ~ 17	21.5	16	15		
17.5 ~ 18	22.5				
18.5 ~ 19	23.5				
19.5 ~ 20	25.5				

Order: UFT. d1

Material: 1.3343 (M2)
Hardness: 62 - 66 HRC