

Locating Punch Code: **KZ2 - KZG**

Reference: FCA / STQ 40007

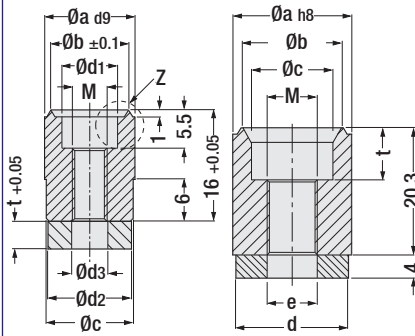

Code: **KZ2**

Code: **KZG**

Order: KZ2 x a

a	b	d1	M	c	d2	d3	t
10	8	6	M4	9.9	9.5	4.2	4
13	11.2	8	M5	12.5	12	5.2	4

Order: KZG x a

a	b	c	M	t	d	e
19	16	13	M8	8	18	8
25	18	16	M10	12	24	9



Marking Stamp Code: **MZG**

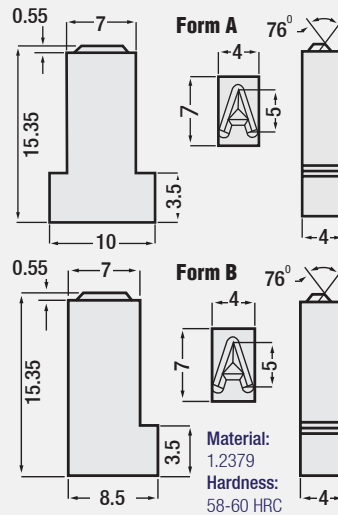

Marking Stamps: Symbol and dimensions can be machined as per request.



Order: **MZG.** Form x Symbol

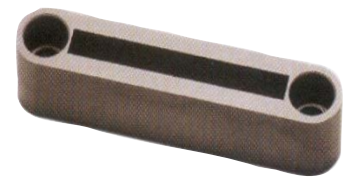

Stamp Retainer Code: **MTU**

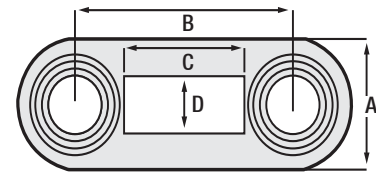

Material: CK45 Hardness: without heat-treatment

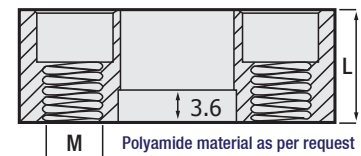

A	B	L	C	D	Pcs.	M
14.90	28	12.0	16.10	7.10	4	M6
	32		20.10		5	
	34		24.10		6	
	44		32.10		8	
	52		40.10		10	



Order: **MTU.** A x B

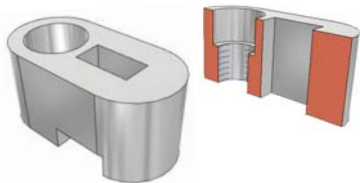

Stamp Retainer Code: **MTG**

Reference: FORD / WDX20-66

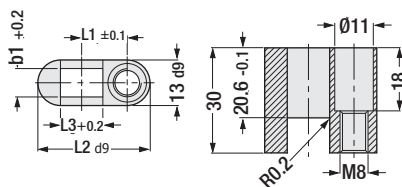

L1	L2	L3	b1
9	24	4.1	8.1
11	28	8.1	
13	32	12.1	
9	24	4.1	6.1
11	28	8.1	
13	32	12.1	



Order: **MTG.** b1 x L1

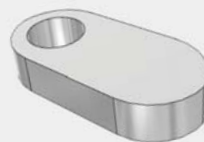

Backing Plate for Stamp Retainer

Reference: FORD

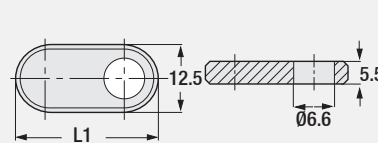

L1	Figure Size
23.5	3.5
27.5	3.5
31.5	3.5
23.5	2.0
27.5	2.0
31.5	2.0



Order: **MEG.** L1 x Figure Size



Backing Plate for Stamp Retainer

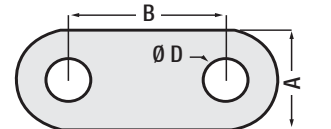

Material: 1.2080 Hardness: 54 - 56 HRC

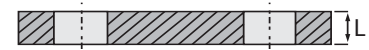

A	B	L	D
15	28	5	6.7
	32		
	36		
	44		
	52		



Order: **MEU.** A x B