

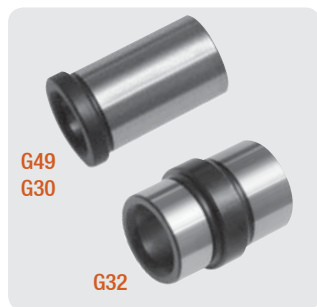

**Guide Pillar (with oil groove)**

Code: **G11**

It can be fixed by thread in cap direction. By disassembling mould / die without dismantling, it provides process iteration advantage. The corners at oil grooves are chamfered (it reduces friction).

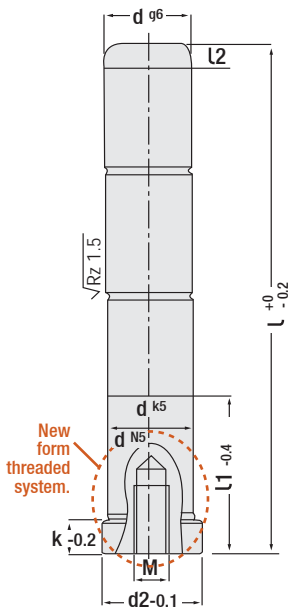

G49  
G30

G32

Order: **G11. d x L**

**Material:** <math>\varnothing 20 = 1.7131</math>  
>   
**Hardness:** 58 - 62 HRC

**Operating Components:** With all unlubricated steel bushes in injection moulds or dies.

d	L	L1	L2	d2	k	M
<b>10</b>	40	13	4	12	3	-
	60					
	80					
	100					
	120					
<b>12</b>	40	18	4	16	6	-
	60					
	80					
	100					
	120					
	140					
<b>14</b>	60	22	4	18	8	-
	80					
	100					
	120					
	140					
	160					
	180					
<b>16</b>	40	16	4	20	8	6
	60					
	80					
	100					
	120					
	140					
	160					
	180					
	200					
	220					
250						
300						

d	L	L1	L2	d2	k	M
<b>18</b>	60	26	4	22	8	8
	80					
	100					
	120					
	140					
	160					
	180					
<b>20</b>	60	28	6	24	8	8
	80					
	100					
	120					
	140					
	160					
	180					
	200					
<b>22</b>	80	37	6	26	15	8
	100					
	120					
	140					
	160					
	180					
	200					
	220					
	240					
	300					
<b>24</b>	80	39	6	28	15	8
	100					
	120					
	140					
	160					
	180					
	200					
	220					
	240					
	300					

d	L	L1	L2	d2	k	M
<b>25</b>	80	35	6	29	10	8
	100					
	120					
	140					
	160					
<b>30</b>	100	45	6	36	15	8
	120					
	140					
	160					
	180					
	200					
	220					
<b>40</b>	160	55	10	48	15	8
	180					
	200					
	220					
	240					
	280					
	300					
<b>50</b>	160	65	10	58	15	8
	200					
	240					
	300					
	360					

**NEW**  
Note:  $\varnothing 25$  Series are added in our stocks.

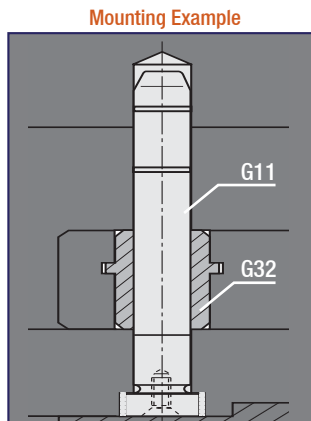

**IMPORTANT!**

**Injection Mould:**

Our guide pillars & bushes cover standard mould systems. But, guide pillar & bushes with different tolerances should be selected for aluminum injection moulds (high temperature / pressure). It should be requested from our company (production with special materials).

**ATTENTION !**

Please do not use two products together that have no oil grooves. One of these products should be oil grooved.