

Slide Retainer - Pinned & Round

Code: **MTY**

Small, round, easy to mount, self-contained design and line contact engagement.

- Three different sizes with retaining ratings loadings for 48, 88 and 176 N.

Material: 1.2767 Hardness: 52 HRC Max. Temp.: 120°C

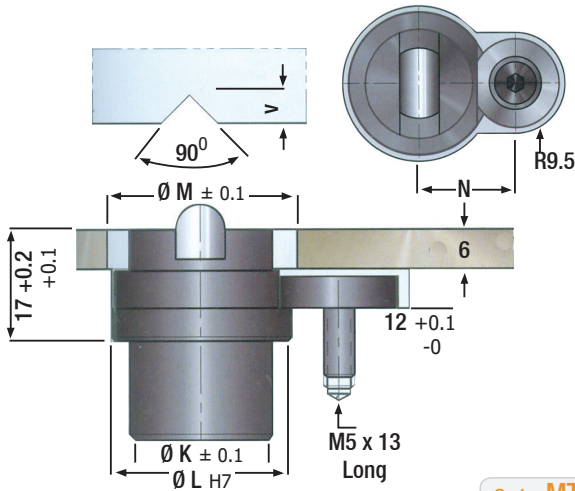
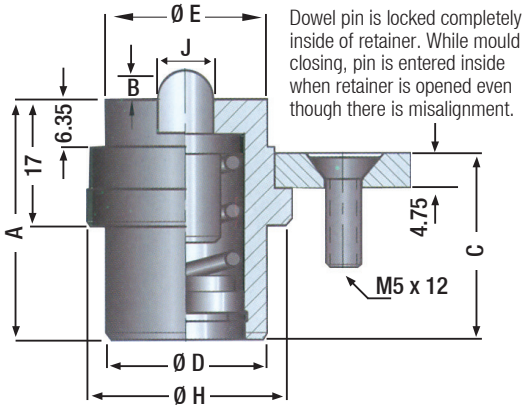

Code: **MTY**

Order	A	B	C	D	E	F
MTY.100	27.43	1.83	20.2	15.75	16	9.52
MTY.200	33.53	3.07	26.29	18.8	19	10.67
MTY.400	32	3.78	24.76	22.1	22	11.86

H	J	V	K	L	M	N	Kgf.
22	4.8	2.3	15.87	22	24	17	4.5
25	6.35	3.9	19.05	25	27	18.2	9
28	7.92	4.9	22.23	28	30	19.4	18

Note: It provides mounting facility to mould, thanks to its robust, small and round structure.

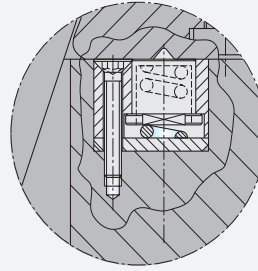

Slide Retainer - Round Type

Code: **MTC**

MTC Slide Retainers are operated without Dowel Pin and also can lift the core / slide without Slide Retainer. Easy mounting due to round structure.

Material: 1.2767 Hardness: 52 HRC Max. Temp.: 100°C

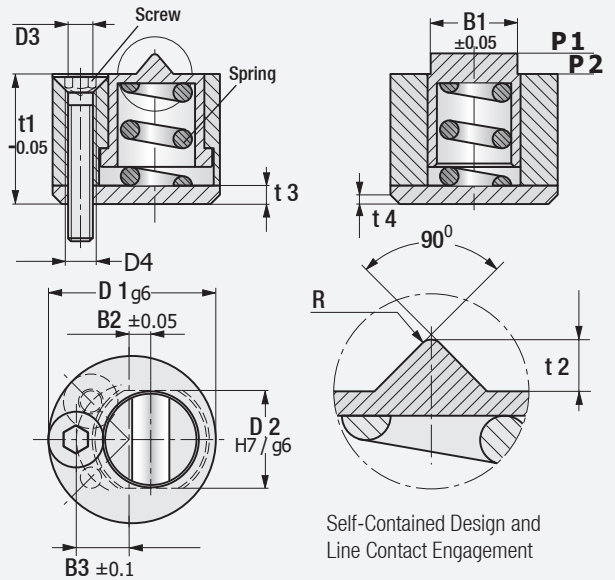

Code: **MTC**

Order	D1	B1	B2	B3	t1	t2	t3
MTC.13	13	6.6	1.4	4.3	10	1.0	1.6
MTC.18	18	9.6	2.0	6.0	14	1.8	2.0
MTC.27	27	14.4	3.0	9.0	21	2.8	3.0

t4	D2	D3	D4	R	P1	P2	Screw (DIN7991)
0.35	7	2.2	M3	0.35	28 Nw	34 Nw	M2 x 16
0.50	10	3.2	M4	0.50	38 Nw	42 Nw	M3 x 50
0.50	15	4.3	M5	0.75	38 Nw	92 Nw	M4 x 25

