

NEW



Code: **GTH.ALO**

Part & Scrap Carrier / Pneumatic Ejector

- Carriage with pneumatic vibration system in very small dimensions, allowing scrap or parts to be removed from the die/tool.
- This system is equipped with a regulator with a capacity of 2 - 5 bar pressure.
- Depending on application requirements, by mean of a slide, different sizes of plates can be applied, this slide is equipped with an adjustment sloping system.
- The operating speed can be adjusted from the brass valve directly inserted in the tool.
- Maximum positioning inclination 20°.

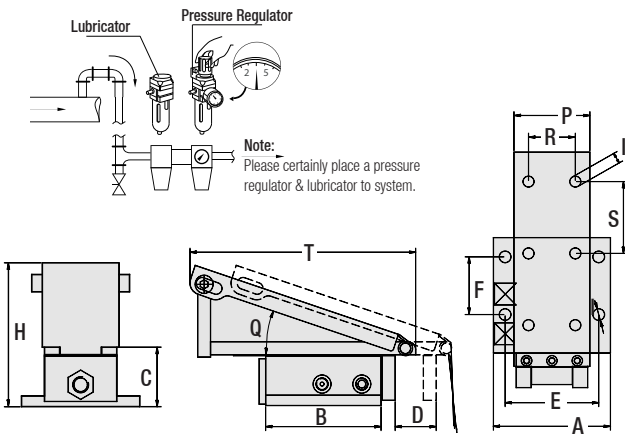

Order Code	Bar	A mm	B mm	C mm	D mm	E mm	F mm	H Max.
GTH.ALO-05	2/5	90	90	29	20	72	45	83
GTH.ALO-10	2/5	90	90	52	35	72	45	105
GTH.ALO-25	2/5	100	106	63	36	82	55	125
GTH.ALO-50	2/5	120	120	72	46	102	96	140

Order Code	I (°)	P mm	Q (angle)	R mm	S mm	T mm	Max. Load
GTH.ALO-05	8.5	58	Max.18° - Min. 7°	36	56	180	5 Kg.
GTH.ALO-10	9	60	Max.20° - Min. 4°	36	56	175	10 Kg.
GTH.ALO-25	9	70	Max.20° - Min. 4°	44	62	190	25 Kg.
GTH.ALO-50	9	96	Max.20° - Min. 4°	56	70	220	50 Kg.

Mounting Example:

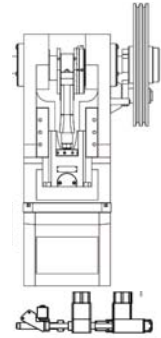
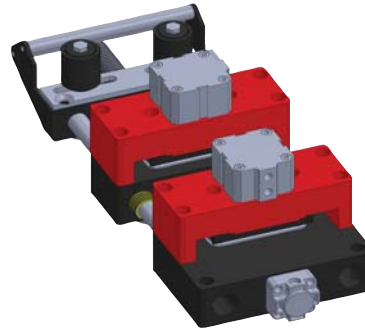
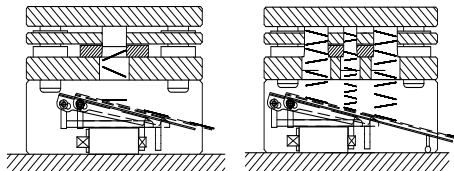

Code: **A.. / E.. / F..**

Pneumatic Feeder

Heavy duty & economic types

- Material width capacity from 100 mm up to 500 mm.
- Material feeding capacity at thickness from 0.2 up to 1.0 / 2.0 / 3.0 mm.
- Feed length from 100 mm up to 300 mm.
- The feeder casings are produced from special aluminum alloy material.
- The bearing column are produced from hard chrome coated material (1080).
- Movable parts are produced from bronze material.
- Feed length set screw are produced from 4140 material.

Order Code	Max. Material Thickness Max. Material Width Feed Length
A1	1 x 100 x 100 (mm)
A2	1 x 100 x 200 (mm)
A3	1 x 100 x 300 (mm)
A11	1 x 150 x 100 (mm)
A12	1 x 150 x 200 (mm)
A13	1 x 150 x 300 (mm)
A21	1 x 200 x 100 (mm)
A22	1 x 200 x 200 (mm)
A23	1 x 200 x 300 (mm)
A31	1 x 300 x 100 (mm)
A32	1 x 300 x 200 (mm)
A33	1 x 300 x 300 (mm)
A41	1 x 400 x 100 (mm)
A42	1 x 400 x 200 (mm)
A43	1 x 400 x 300 (mm)
A51	1 x 500 x 100 (mm)
A52	1 x 500 x 200 (mm)
A53	1 x 500 x 300 (mm)
E1	2 x 150 x 100 (mm)
E2	2 x 150 x 200 (mm)
E3	2 x 150 x 300 (mm)

Order Code	Max. Material Thickness Max. Material Width Feed Length
E11	2 x 200 x 100 (mm)
E12	2 x 200 x 200 (mm)
E13	2 x 200 x 300 (mm)
E21	2 x 300 x 100 (mm)
E22	2 x 300 x 200 (mm)
E23	2 x 300 x 300 (mm)
E31	2 x 400 x 100 (mm)
E32	2 x 400 x 200 (mm)
E33	2 x 400 x 300 (mm)
E41	2 x 500 x 100 (mm)
E42	2 x 500 x 200 (mm)
E43	2 x 500 x 300 (mm)
F1	3 x 150 x 100 (mm)
F2	3 x 150 x 200 (mm)
F3	3 x 150 x 300 (mm)
F11	3 x 200 x 100 (mm)
F12	3 x 200 x 200 (mm)
F13	3 x 200 x 300 (mm)
F21	3 x 300 x 100 (mm)
F22	3 x 300 x 200 (mm)
F23	3 x 300 x 300 (mm)

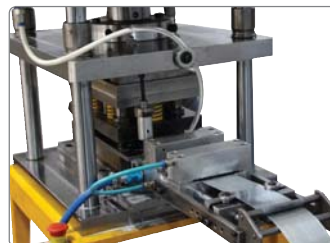

Made in Turkey

- + **Güvenal Service**
- + **Spare Parts**
- + **Periodic Maintenance Assurance**