

Ejector Pin with Locking Head (Anti-Rotating)

The new generation of ejector pins with locking head allows the precise centring of individually contoured ejector or core pins in the mould. The centring ensures a precise mounting position within the mould.

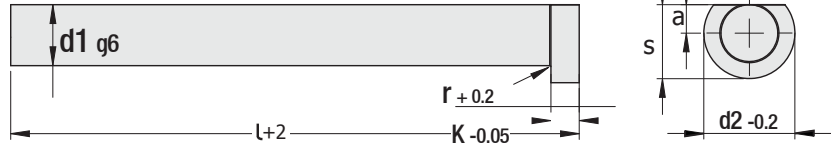
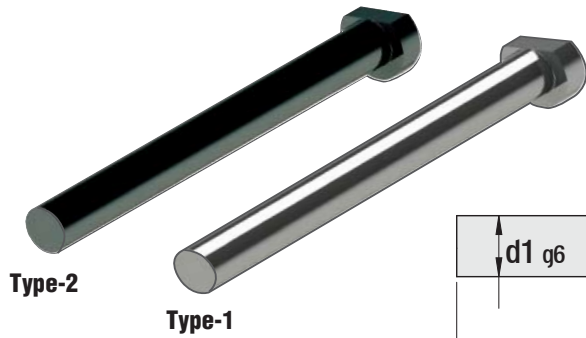

Type-1

Material: 1.2516 WS
Head Hardness: 45 ± 2 HRC
Body Hardness: 60 ± 2 HRC
Heat Resistance: 220^o max.
Tensile Resistance: 1300 N / mm²

Type-2

Material: 1.2343 Plasma Nitrided + Oxidation Coated
Heat Resistance with Lubricating Grease: 1400^o max.
Heat Resistance: 650^o max. (without lub. grease)
Head Hardness: 45 ± 5 HRC

Body Hardness: 44 HRC
Oxidation Clad Body Hardness: 70 HRC
Tensile Resistance: 1450 N / mm²

d1	l	d2	K	a	s
3.0	100	6	3	1.5	4.5
	125				
	160				
	200				
	250				
	315				
3.5	100	7	3	1.75	5.25
	125				
	160				
	200				
	250				
4.0	100	8	3	2	6
	125				
	160				
	200				
	250				
	315				
4.5	100	8	3	2.25	6.25
	125				
	160				
	200				
	250				
5.0	100	10	3	2.5	7.5
	125				
	160				
	200				
	250				
	315				
	400				
	500				

d1	l	d2	K	a	s
5.5	100	10	3	2.75	7.75
	125				
	160				
	200				
	250				
6.0	100	12	5	3	9
	125				
	160				
	200				
	250				
7.0	100	12	5	3.5	9.5
	125				
	160				
	200				
	250				
	315				
7.5	100	12	5	3.75	9.75
	125				
	160				
	200				
	250				
	315				
8	100	14	5	4	11
	125				
	160				
	200				
	250				
	315				
	400				
	500				

d1	l	d2	K	a	s
8.5	100	14	5	4.25	11.25
	125				
	160				
	200				
	250				
	315				
9	100	14	5	4.5	11.5
	125				
	160				
	200				
	250				
10	100	16	5	5	13
	125				
	160				
	200				
	250				
	315				
	400				
	500				
11	100	16	5	5.5	13.5
	125				
	160				
	200				
	250				
	315				
	400				
	500				
12	100	18	7	6	15
	125				
	160				
	200				
	250				
	315				
	400				
	500				

d1	l	d2	K	a	s
14	100	22	7	7	18
	125				
	160				
	200				
	250				
16	100	22	7	8	19
	125				
	160				
	200				
	250				
	315				
20	100	26	8	10	23
	125				
	160				
	200				
	250				
	315				
25	100	32	10	12.5	28.5
	125				
	160				
	200				
	250				
	315				
	400				
	500				

Note: Our custom-made production is available as per request.

Order: SDI. d1 x l x Type