

## Clamps for Guide Components

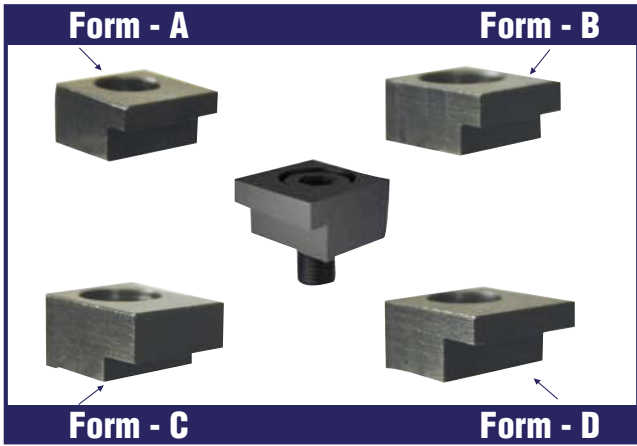

### Guide Bush Clamp Form: A-B-C-D Code: G102

It is used to fix from cap or flange portion at guide pillar and self lubricating bush. While using for self-lubricating guide bushes and other bush components with bushes for  $\varnothing \leq 63$  - 2 pcs. and for  $\varnothing \geq 80$  - 3 pcs. clamps are used. Mounting screws should be supplied separately.

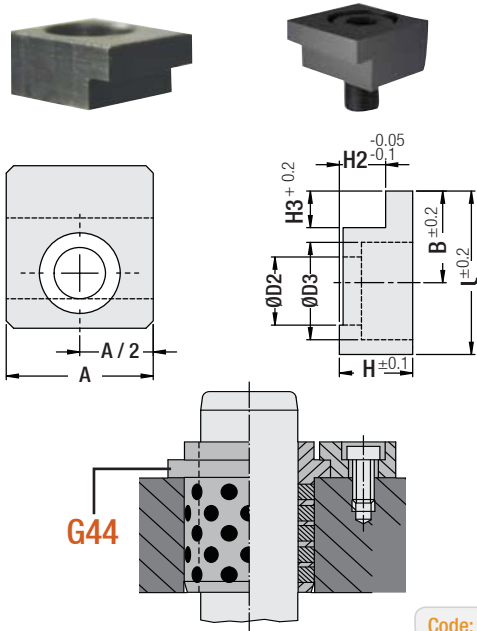

Code: G102

$\varnothing d - d1$ Pillar / Bush	A mm	B mm	L mm	H mm	H2 mm	H3 mm	D2 $\varnothing$	D3 $\varnothing$	Form Screw
25 - 32 40 - 50	20	12.5	20	10	6.3	5	7	11	A M6x16
63 - 80 100 - 125 160	20	15	25	12	6.3	5	9	15	B M8x20
63 - 80 100 - 125	25	21	32	16	6.3	10	11	18	C M10x20
63 - 80 100 - 125 160	32	21	32	16	10	10	11.5	17.5	D M10x20



Order: G102. Form

Order Example:

G102.A

**Guide Pillar & Bush Clamp** Order Code: G100

Can be used in clamping of demountable guide pillars (G10 - G15 - G01 - G08) in clamping system of guide pillars.

**Guide Pillar & Bush Clamp** Code: G143

Thick and walled clamps used in clamping of guide pillar / bush sets in dies.

Form Screw	A	B	K
A M6	6.20	4.80	2.5
B M8	8.40	5.80	4

Order: G143. Form Order Example: G143.B

**NEW**

**Hex-socket Button Head Screw with Flange** Code: IMBF

ISO 7380-2 10.9 Zinc Plated

d	l	d1	d2	SW
M6	10	13.6	3.3	4
	12			
	16			
M8	16	17.8	4.4	5
	20			
M10	20	21.9	5.5	6

Mounting Example

Order: IMBF. d x l