

## Accessories for Combined Power Sliding Clamps

### Upper Slide Part

- Forged Steel / Hardened





Order Code	T-Slot 	h Min. - Max.	SW	SW	Weight (g)
1120-0050	14 - 18	0 - 50	8	-	860
1130-0060	14 - 22	0 - 60	10	-	1680
1150-0062	18 - 28	0 - 65	12	-	2565
1160-2080	22 - 36	20 - 80	12	24	5050

### Body with T-Slide

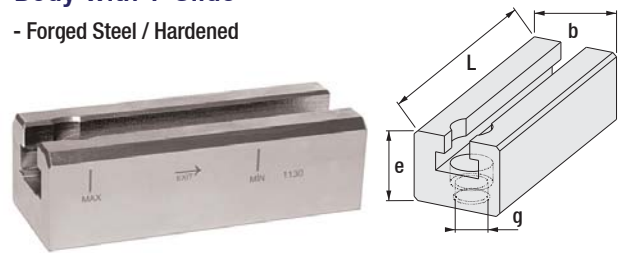
- Forged Steel / Hardened





Order Code	 g (metric)	T-Slot 	L	b	e	Weight (g)
1120-045	M10 / M12	14 - 18	104	38	35.5	750
1130-047	M12 / M16	18 - 28	130	48	39	1275
1150-053	M16 / M18 / M20	18 - 28	140	55	42	1700
1160-074	M20 / M22 / M24	22 - 28	178	74	55	3650
1160-075	M30	36	178	74	55	3650

### Base Support

- Forged Steel / Hardened



Order Code	 g (metric)	T-Slot 	L	b	e	Weight (g)
1120-040	M10 / M12	14	104	38	38	820
1130-045	M12 / M16	14	130	48	45	1630
1150-048	M16 / M18 / M20	18	140	55	48	2070
1160-059	M20 / M22 / M24	28	178	74	59	3980

### Clamping Screw Set

- Class: 10.9 / Black Coated

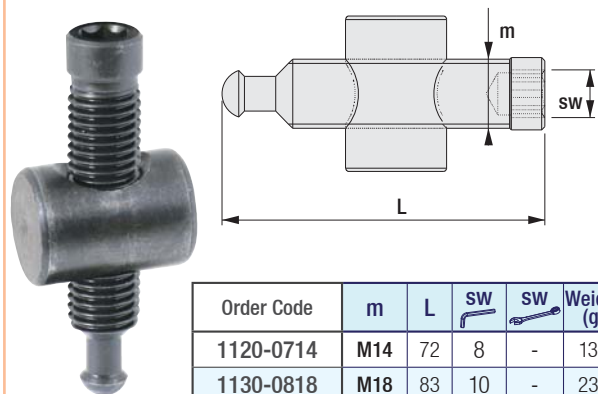

Order Code	m	L	SW	SW	Weight (g)
1120-0714	M14	72	8	-	138
1130-0818	M18	83	10	-	235
1150-0920	M20	96	12	-	360
1160-1024	M24	134	12	24	795

### Hex-socket Screw for Fixing

- For M12 - M16 - M18 - M20 thread holes.

- Class: 10.9 / Black Coated

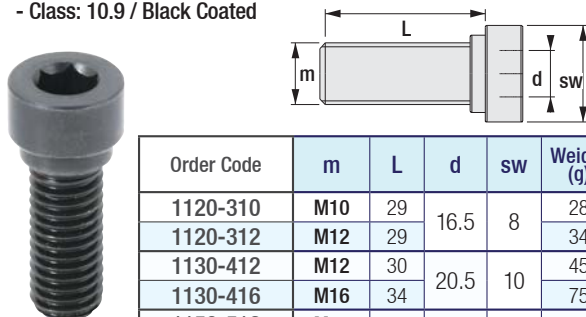

Order Code	m	L	d	sw	Weight (g)
1120-310	M10	29	16.5	8	28
1120-312	M12	29			34
1130-412	M12	30	20.5	10	45
1130-416	M16	34			75
1150-516	M16	34	24.5	12	75
1150-518	M18	38			90
1150-520	M20	38			105
1160-620	M20	45	34	12	170
1160-622	M22	49			295
1160-624	M24	45			390
1160-724	M24	55			405
1160-730	M30	66			450

