

NEW



Support Bolt

Code: **G159**

These bolts form a gap on mould surfaces in order to prevent damage to water unions and cooling hose systems protruding on injection mould surfaces and hydraulic - pneumatic core systems. Minimum four bolts should be used according to each mould size. Especially, it is used to protect protruding parts of moulds during shelf forming.

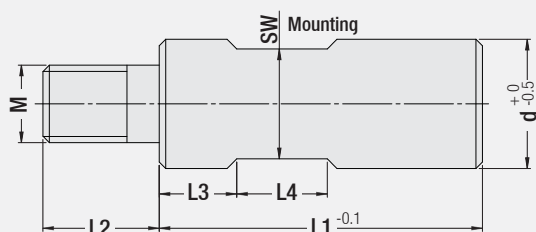

d - 0.5	M Metric	L1 mm	L2 mm	L3 mm	L4 mm	SW Mounting
20	M12	35	18	14	12	17
		50				
		80				
32	M16	35	24	18	12	27
		50				
		80				
39	M20	80	30	24	16	32
		120				

Mounting Example

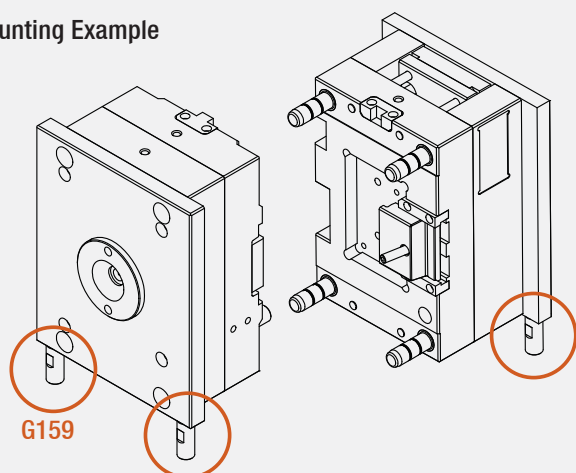

Order:
G159. d x L1

Material: CK45



CE

Mould Safety Latch

Code: **G103**

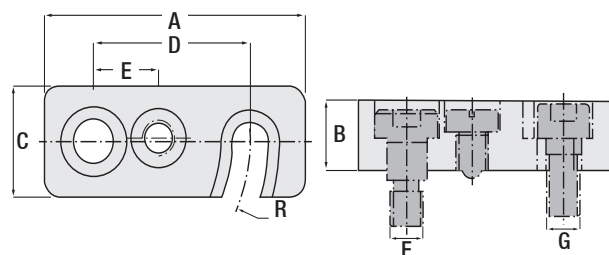

A mm	B mm	C mm	D mm	E mm	F mm	G mm	R rdy
50	12	20	30	14	M6	M6	30
63	16	25	38	17	M8	M8	38
80	20	32	48	20	M10	M10	48



Order:
G103. A

Material: 1.0503 Steel
Forging Sandblasting

Mould Safety Latch: This system is mounted outside of the mould. It is used to carry the mould safely. It is fixed on the mould with a cylinder head cap screw. Other cylinder head cap screw hole is drilled at the opposite party. Mounting or demounting can be easily done with spring plunger. It is a compact product having no loose parts. It has no protruding parts as a clamping lock.

safe transport position

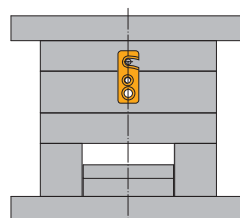

in working position

