

Equipment used in Hot Runner Systems:



Manifold Inlet

Code: SA

Inlet is the first element that provides the start of distribution of melt raw material into Manifold.

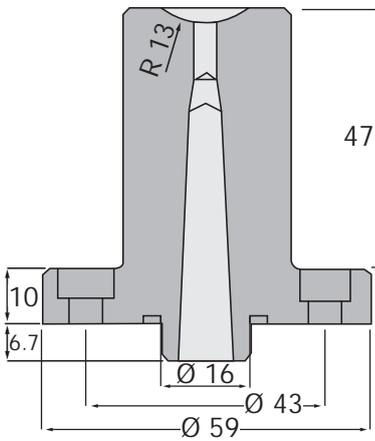

Order: SA0100V02



Stopping Disc

Code: SD03

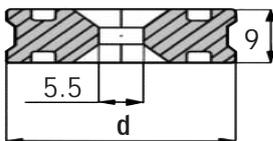

Order Code	d
SD03.00V02.28	28 mm
SD03.00V02.34	34 mm

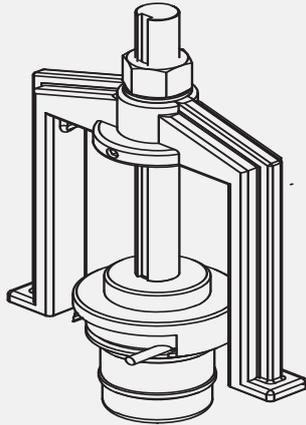

Extractor Tool for Hot Runner Nozzle

Code: MCA

In extractor process of Hot Runner Nozzles from mould plate, it is used in extractor / dismantle processes not to damage Hot Runner Nozzles.

D: 18 - 22 - 25 - 32 - 40 mm

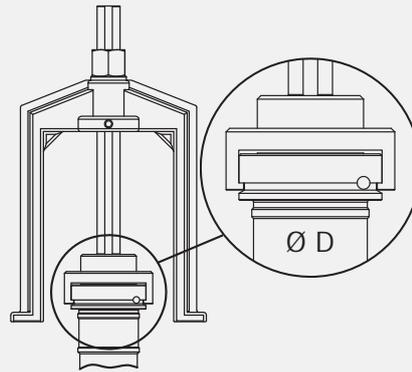

Order: MCA



Hub Disc

Code: SD02

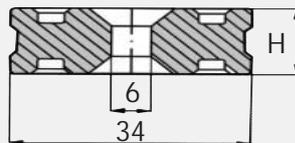

Order Code	H
SD02.00V01.13	13 mm
SD02.00V01.20	20 mm

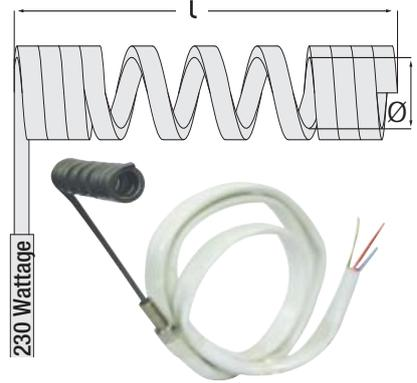

Coil Heater

Code: SR

For necessary information; please refer to page-325.

Heaters (wattage)
200
225
250
290
350
400
470
620

Heaters (wattage)
690
850
950
1100
1200
1400
1600

Mantle Thermocouple

Code: MT015

"In Valve Gate System Hot Runner Nozzles"

It is a Thermocouple providing to make precision temperature from body.

Note: "d1" and "L" dimensions can be produced as per request.

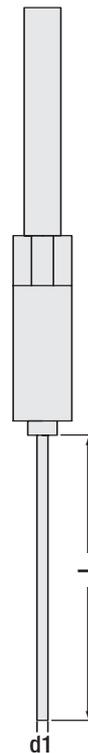

Order Code	d1	L
MT01580	Ø 1.5 mm	80
MT015100		100
MT015120		120