

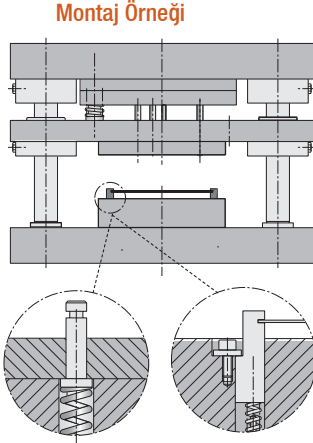

## SAC KALDIRMA PİMİ

Kılavuz Kolon **Kod : G.23**

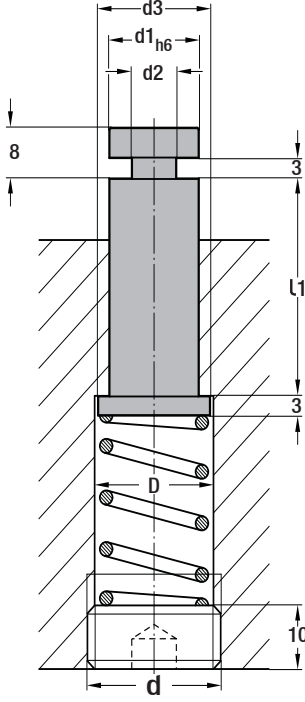

Progresif - Çok Aşamalı Form Verme Kalıplarında Sacı Hizaya Alma ve Taşıma Amaçlı Olarak Kullanılır. Kurulum İçin (G.145 - Çelik Yay) Ünitelerden Yararlanılabilir.

## Yuvarlak Çelik Yay

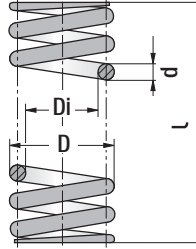

## Sac Kaldırma Yayı

D	Di	d	L
10.5	8.5	1.5	40
12.5	10.5	1.5	55
16.5	13	2	40
21	17	2.5	40

L : Yay Boyu / Kalıp Plakası Ölçülerine Göre Seçim

## Sac Kaldırma PİMİ **Kod : G.23**

d1 h6	L1 mm	Ø d2	Ø d3	D d
8	20	5	10	10.5
	25			
	32			
	40			
10	25	6	12	12.5
	32			
	40			
	50			
13	25	7	16	16.5
	32			
	40			
	50			
16	32	8	20	21
	40			
	50			

## YAY SIKIŞTIRMA AYAR VİDASI **Kod : G.145**

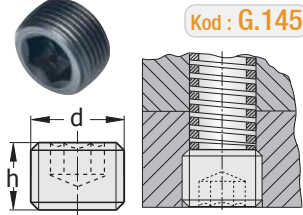

d Diş	dh Yuva	h Boy	SW Allen
<b>M.12 x 1.5</b>	10.5	10	6
<b>M.14 x 1.5</b>	12.5	10	6
<b>M.18 x 1.5</b>	16.5	10	8
<b>M.22 x 1.5</b>	20.5	10	8

Sipariş : G.23 x d1x L1

Sayfa  
46

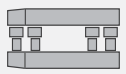

Bölüm  
Pres  
Kalıp

Kullanım : Pim + Çelik Yay  
Yay Sıkıştırma Ayar Vidası ile  
Sertlik : 58-60 HRC



## BASKI PİMLERİ **Kod : G.69.B**

Baskı Pimi

Referans : VW / AUDI 39D 638

L : Siparişe Göre Belirlenir.

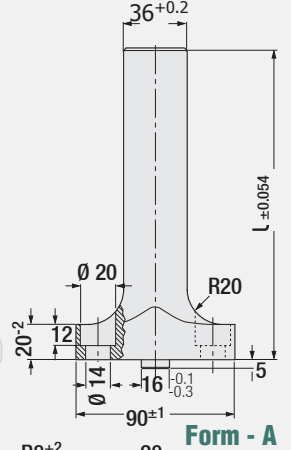

Form - A

Form - B

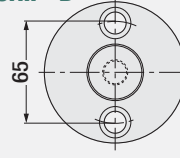

Form - C

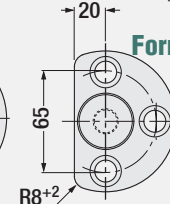

Form - D

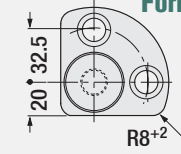

Sipariş	Form	L
G.69 Form A	A	İsteğe Göre
G.69 Form B	B	
G.69 Form C	C	
G.69 Form D	D	

Ünitelerin Montajında Kullanılan  
Cıvatalar Kullanıcı Tarafından  
Temin Edilir.

Malzeme : 1.0503 (C45)

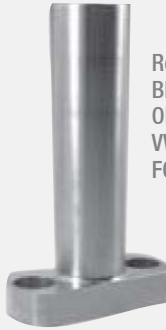

## BASKI PİMLERİ **Kod : G.69**

Baskı Pimi

Referans :  
BMW B2 2615 12  
OPEL F33 15  
VW AUDI 39D 638 - 1  
FORD WDX 17 - 7M

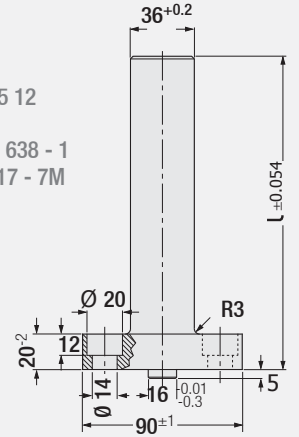

Sipariş	L
G.69.110	110 mm
G.69.150	150 mm
G.69.160	160 mm
G.69.175	175 mm
G.69.200	200 mm
G.69.225	225 mm
G.69.250	250 mm
G.69.275	275 mm
G.69.300	300 mm
G.69.325	325 mm
G.69.400	400 mm

Ünitelerin Montajında Kullanılan  
Cıvatalar Kullanıcı Tarafından  
Temin Edilir.

L : Siparişi Tablo Verilerinde Ayrıca  
İsteğe Göre Boylarda

Malzeme : 1.0503 (C45)