

NEW



### Laminar Gas Vent

Order Code: **LV.483610**

Helps venting the mould cavity and the pneumatic ejection of the plastic part (allows air passing in both directions). Maximize performance installing at the end of the plastic flow. Supplied with 6 covers for maintenance purposes. Also designed for use with Cumsa VB and SV systems.

Material: 1.4021

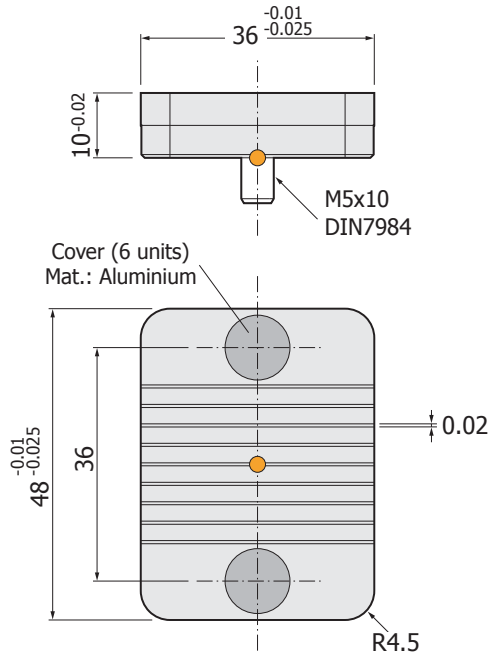

**Pocket / Housing Detail:**

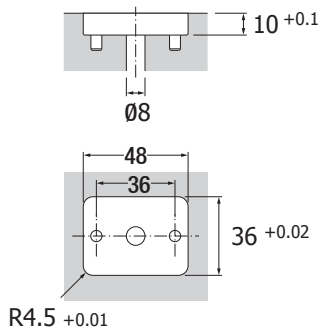

### Gas Venting Filter for Diecasting (aluminium & zamak moulds)

Code: **AHV**

It is designed / produced with heat treated and large discharge poles. It is a specially designed and highly productive product for Diecasting Moulds & Injection Moulds.

The service life of the product is longer than the equivalent products. You can minimize product replacement times by increasing productivity levels.

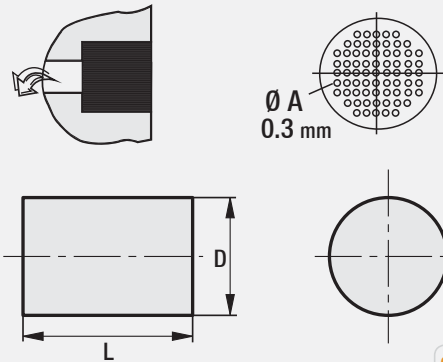

Code: **AHV**

Order	D (Ø)	L (mm)	A (Pore pcs.)
AHV.03	3.0	10	40
AHV.04	4.0	10	40
AHV.05	5.0	10	90
AHV.06	6.0	10	90
AHV.08	8.0	10	200
AHV.10	10	10	340
AHV.12	12	10	340
AHV.16	16	15	340
AHV.20	20	15	550

It is resistant to high temperature and pressure.

