



Slide Unit

Code: SU

Ideal to de-mold external details. Compact unit with strokes up to 5mm. Slider is made from two different inserts, allowing flexibility regarding the molding feature. All machining can be made 90° to parting line. Easy to change molding inserts due to fixing method. Incorporates a slide retainer and an angle pin.

Material: 1.2344
Hardness: 54 ± 2 HRC
 Patented System

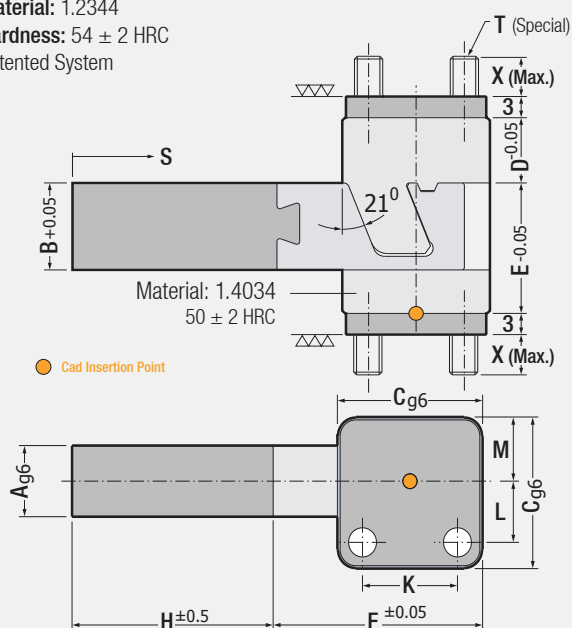

Code: SU

Order	A	B	C	D	E	F	H
SU.081220	8.2	12	20	10	18	28	32
SU.121626	12.2	16	26	12	24	37.5	36
SU.162032	16.2	20	32	16	30	46.5	40

K	L	M	R	S	T	X
12.5	8.25	8	3.75	3	M4	6.2
17	10.5	11	4.5	4	M5	7.2
22	13	14	5	5	M6	9.2

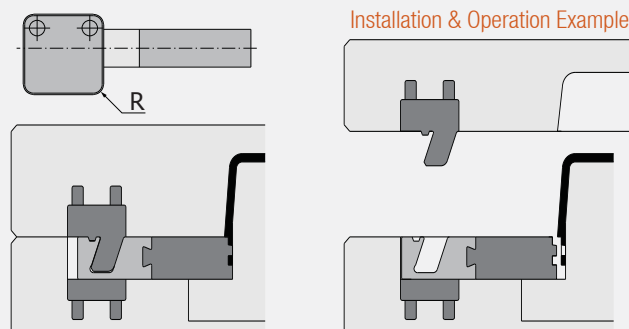

Undercut Unit

Code: UU

Inverse movement regarding normal units, ideal for de-moulding internal detail. Compact unit with strokes up to 5mm. Slider is made from two different inserts, allowing flexibility regarding the molding feature. All machining can be made 90° to parting line. Incorporates a slide retainer and an angle pin.

Material: 1.2344
Hardness: 54 ± 2 HRC
 Patented System

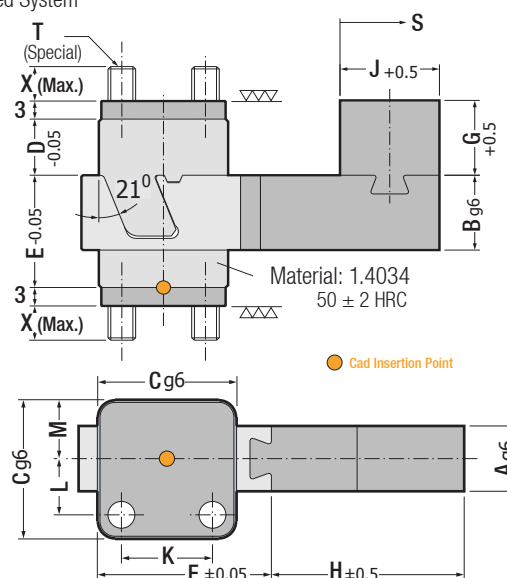

Code: UU

Order	A	B	C	D	E	F	G
UU.081220	8.2	12	20	10	18	24.5	12
UU.121626	12.2	16	26	12	24	32.5	16
UU.162032	16.2	20	32	16	30	41	20

H	J	K	L	M	S	R	T	X
32	16	12.5	8.25	8	3	3.75	M4	6.2
36	20	17	10.5	11	4	4.5	M5	7.2
50	25	22	13	14	5	5	M6	9.2

